

DAVI

MCA 4 Roll

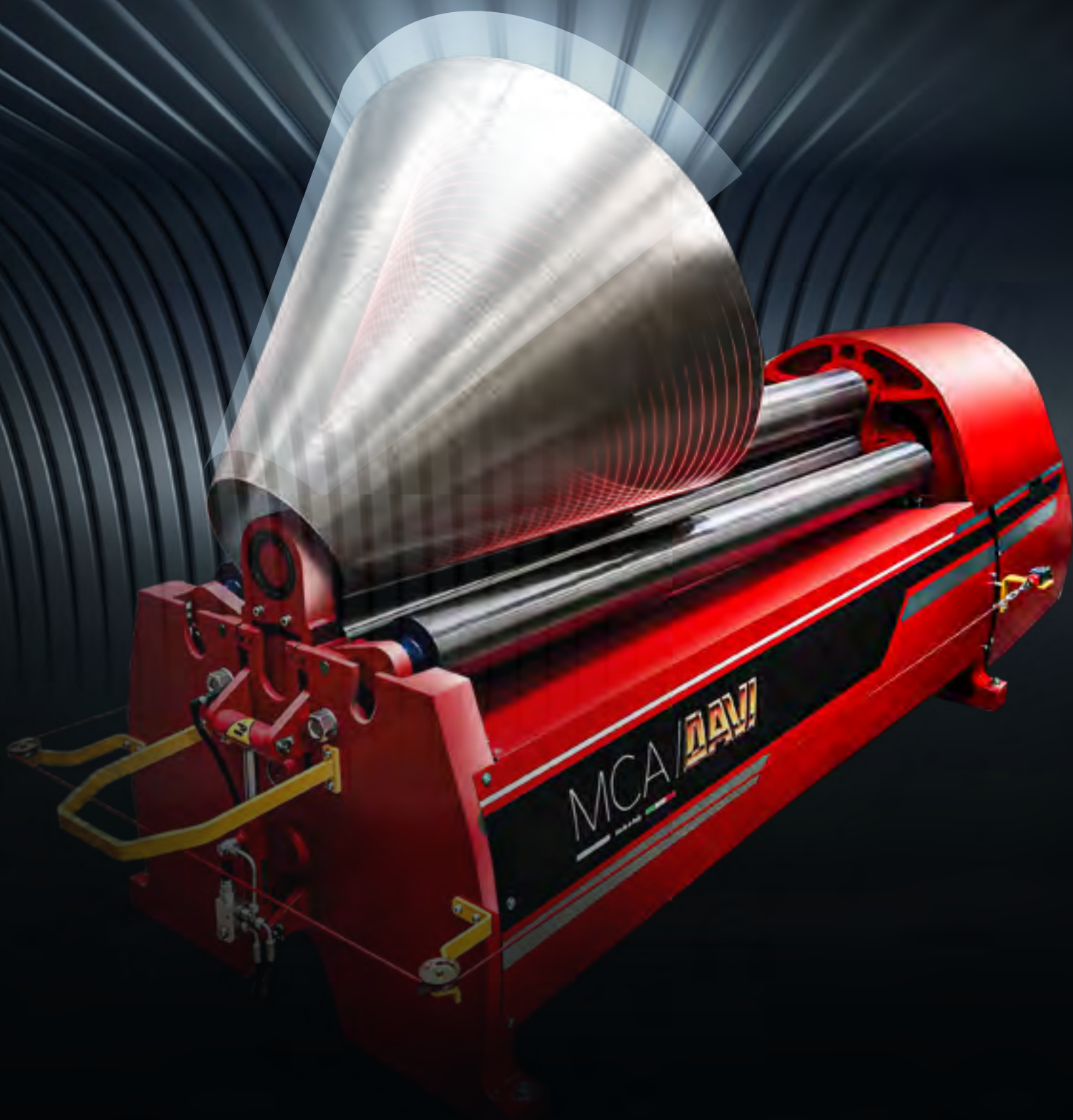

Mission

01

We work hard to be the partner of choice whenever companies need to roll Metal Plates and Sections. We strive to be by the customers' side for any rolling work they have to carry on.

02

This goal has deep roots in the past, with the rolling challenges we overcame in our history since 1966, studying the specific needs of customers and finding the best way to go on together.

03

This goal is very clear in the present: our daily task is to support our current customers and to invest in research and development for being at the forefront of rolling innovation.

04

This goal sets clear projects for the future: our financial strength and our solid structure grant the continuity of our business and the support we will be able to give in terms of both service and new solutions.

DAVI

Davi is since more than a decade the world largest manufacturer of Plate Rolls, Angle Rolls, High Productivity Lines and Customized Rolling Machines in terms of sales volume, employees, range, production, assets and rating. In fact, Davi has been awarded 'Prime Company' and given maximum commercial reliability by Dun & Bradstreet and holds all the ISO Certifications (Quality ISO 9001, Environmental ISO 14001, Safety ISO 45001).

Since 1966, Davi has been committed in Research & Development with the goal of finding the best Rolling Solutions for the global market.

Davi headquarters are located in Italy, where all Plate and Angle Rolls are manufactured and then delivered all around the world, while the Sales & Service network is comprised of two branches in the United States and China and more than a hundred dealers in the five continents.



MCA - 4 Roll Plate Rolling Machine

Whenever repeatability, productivity and ease of use are of essence, MCA 4 Roll is the technology of choice



EXTREME
4Roll

The new Frontier of Control System

Ergonomic console and high-res interface for a throughput maximized thanks to Davi AI (Artificial Intelligence)

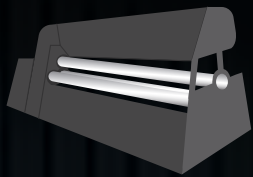

Special Solutions for your Needs

thanks to the highest level of Customization on the market

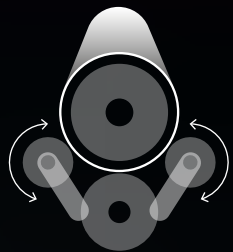

Tightest Achievable Diameters

thanks to Planetary Guides

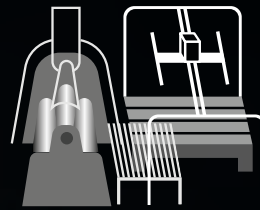

Highest Automation

with Rolling Lines powered by state-of-the-art Control System

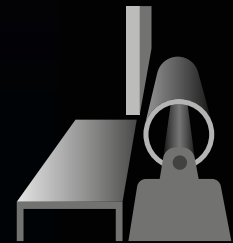

Plate Roll Ready for Upgrade

thanks to built-in provision for Retrofitting



Best Rolls Parallelism

thanks to patented Servo-Tronic® system

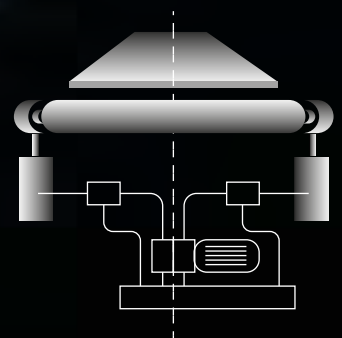

Easy Installation, Great Operability and Maintainability

with our on site or remote Assistance always available

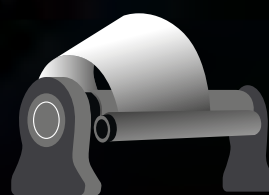

Perfect Extreme Cones

thanks the low frame

Automation

Industry 4.0 is changing the way Fabricators see, plan, organize their workshops.

Davi MCA Plate Rolls are equipped with state-of-the-art Control Systems, specifically designed by Davi R&D Department to help you getting the most out of your 4 Roll Plate Rolling machine.



Davi Control System, tailored for the highest possible level of automation on the Market, features the possibility of automatically generating a full program importing the workpiece CAD file, recalling workpiece data from local network database through a barcode reader-based system and making use of offline Capacity and Spring-back Performance Test.

Thanks to Davi Control System all operators will finally have the ability to match the required tolerances with maximum repeatability: a real boost to competitiveness.



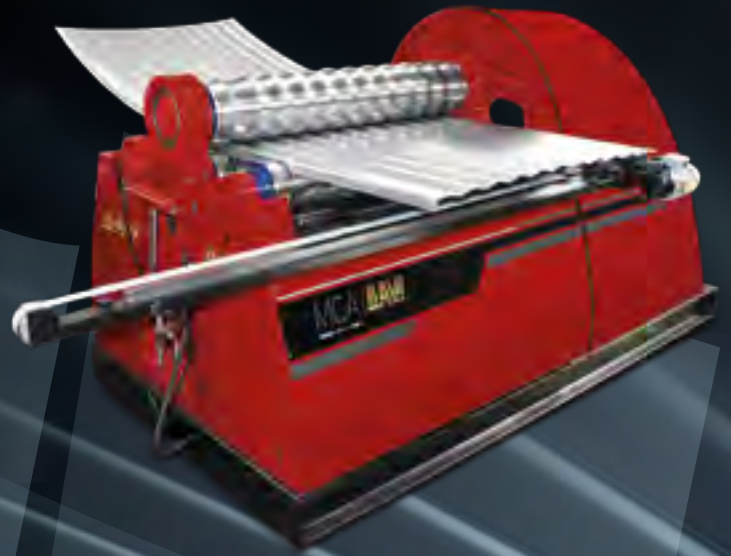

Customization

When it comes to Rolling, fabricating strategies require expanding the stand-alone Plate Roll capabilities with customized accessories, with different goals: from more accurate Plate Handling to enhanced Feeding Systems, from manufacturing Extreme Cones to reaching very Tight Diameters.

Upgrades

MCA 4 Roll Machines are designed for allowing easy retrofit of accessories!

Davi Sales, After Sales and Research & Development Departments will work together and suggest the customers the most appropriate retrofitting strategy, including the recommended accessories for the client's needs.





In order to obtain Complete Management on the whole Manufacturing Process, for many years Davi has created a solid partnership with Suppliers, High-level Companies with production sites in the most skilled areas of Italy.

Throughout the entire flow, Davi is committed to ensure an Integrated Quality Control with the aim of ensuring the highest quality standards on the Market.

Customer support

Remote Support

Davi Specialized Team can connect remotely with every corner of the world and improve the customer's uptime



On Site

On site intervention can be performed on both Davi Machines and other brands: from Installation to Commissioning, from Training to Preventive Maintenance



Production in numbers



100

Plate and Angle
Rolls always
available and
ready for delivery

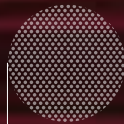

300

Plate and Angle
Rolls produced
every year

10,000

More than 10,000
Plate and Angle
Rolls installed
worldwide

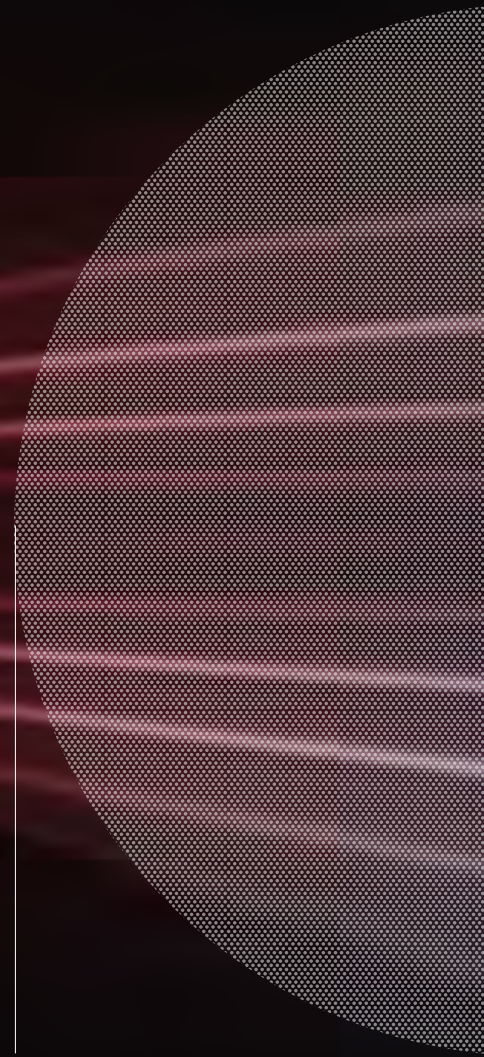



Research & Development

Engineering Everyday Challenges

Davi Sales and Technical Teams are always ready to exchange ideas with Customers, in order to get a full comprehension of the Rolling Challenge they have to face. Davi R&D wants more, and strives to offer innovative solutions to problems customers didn't even think of!



Technical specifications

Model	Roll Width feet	Rolling Thickness inch	Pre-bending Thickness inch	Top Roll Diameter inch	Bottom Roll Diameter inch	Electric Power HP
MCA 2017	6 ft. 6"	9/32"	5/32"	6.5"	6.5"	6.6
MCA 2019	6 ft. 6"	3/8"	1/4"	7.5"	7"	6.6
MCA 2020	6 ft. 6"	7/16"	5/16"	8"	7.5"	12
MCA 2024	6 ft. 6"	5/8"	1/2"	9.5"	9"	18
MCA 2520	8 ft. 2"	5/16"	1/4"	8"	7.5"	6.6
MCA 2522	8 ft. 2"	3/8"	5/16"	9"	8"	12
MCA 2527	8 ft. 2"	5/8"	1/2"	10.5"	10"	18
MCA 3018	10 ft. 2"	5/32"	14Ga	7"	6.5"	6.6
MCA 3020	10 ft. 2"	9/32"	5/32"	8"	7"	6.6
MCA 3022	10 ft. 2"	3/8"	1/4"	9"	8"	12
MCA 3028	10 ft. 2"	9/16"	3/8"	11"	10"	18
MCA 3030	10 ft. 2"	5/8"	1/2"	12"	11"	18

Davi manufactures machines of all types and dimensions which, due to lack of space, cannot be published in full. Upon request, offers can be drawn up for machines of all performance levels; Davi in fact has the technical, design and production expertise to cope with any bending application.

The above mentioned capacities are based on mild steel with max 65,000 Psi UTS (Ultimate Tensile Strength) and 40,000 Psi as YIELD (Elastic limit). Tighter diameters can be achieved by reducing material thickness, width or tensile strength. On different materials, capacities may vary from our standard.



EN 07/23

DAVI

www.davi.com

DAVI INC.
15107, Surveyor Boulevard, Addison, TX - 75001
Ph. (972) 661-0288 - Toll Free (888) 282-3284 - davi-inc@davi.com

**LOGISTIC AND
ACCESSORY CENTER**
Texas

LOGISTIC CENTERS
Illinois - Missouri
Texas - Arizona