

SOLUTION

marvel[®] —SERIES— VT4555

VT4555 (8-MARK-II) • VT4555M (8-MARK-III)



The Worlds Most Popular
Vertical Tilt-Frame Bandsaw



◀ Also Available In
MARVEL CLASSIC

CAPACITY: 18" X 22"
OPTIONAL HIGH COLUMN CAPACITY: 18" X 28"
VT4555 BLADE WIDTH: 1" • VT4555M BLADE WIDTH 1.25"



AMADA[®]
AMADA MACHINERY AMERICA, INC.

THE WORLDS MOST POPULAR VERTICAL TILT-FRAME BAND SAW

marvel[®] VT4555 —SERIES—

VT4555 (8-MARK-II) = 1.00" Blade Width • Manual Column Return

VT4555M (8-MARK-III) = 1.25" Blade Width • Semi-Automatic



WISSES



STANDARD FEATURES

- **SPEED RANGE:** 50-450 fpm (15-137 m/min) infinitely variable with inverter drive.
- **FRONT-MOUNTED SPEED CONTROL:** Allows blade speed to be adjusted from operator's control station.
- **FEED RANGE:** 0-140 lbs. (64 kgf) infinitely variable direct reading scale balance beam on VT4555. 0-250 lbs. (113 kgf) infinitely variable with control on operator's panel and Automatic Column Return. Column feed is mechanical with Amada Marvel clutch power feed on our VT4555M.
- **T-SLOTTED WORK TABLE:** Work area 24.25" x 33" (616 mm x 838 mm); table height 34.5" (876 mm); four machined T-slots accept .625" (15.5 mm) T-Bolts on our VT4555. Work area 24.25" x 33" (616 mm x 838 mm); Table height 38" (965 mm); Two machined T-slots on our VT4555M.
- **0° - 3° CANTED COLUMN:** Adjustable 0 or 3° forward approach angle, for notching, or increased efficiency in cutting of structural materials. (only available in VT4555M (8-MARK-III))
* VT4555 (8-MARK-II) is not adjustable and is available in either 0° or optional 3° Cant.
- **MITER CUTTING:** Column and blade tilt up to 45° on VT4555 and up to 60° right and left of vertical on the VT4555M. Optional Powered Tilt only available on the VT4555M.
- **QUICK-ACTION VICE:** Maximum opening 18" (457 mm). Jaws can be shifted to either right or left side of blade. Jaws are 6" (152 mm) high, 12" (305 mm) wide.
- **AUTOMATIC STOPS:** Adjustable stops can be pre-set to stop advance and return of blade, and also to stop motor at any location within the 18" (457 mm) travel of the blade.
*VT4555 (8-MARK-II) doesn't have auto return feature.
- **FLUSHING HOSE:** Washes chips from hard to get at places reducing clean-up time.
- **POWER CHIP BRUSH:** Together with blade wipers and flood coolant deep blade teeth free of chips.
- **EAGLE BEAK VTR BLADE:** Eagle Beak VTR blade with 3/6 tooth pitch. This is the standard blade that is included with machine purchase.

MOST POPULAR OPTIONAL FEATURES

- **M6: HIGH COLUMN**
- **8SP01337: LASER LIGHT**
- **DRO: DIGITAL TILT READOUT**
- **M3M: POWERED COLUMN TILT**
- **E4: SECOND STANDARD VISE**
- **ML2: MIST LUBE- AUTOMATIC**
- **M9A: VARIABLE VISE PRESSURE**
- **8/F055: DEAD ROLLER CONVEYOR**
- **E14: AIR POWERED VISE**

*Pictures may include some optional equipment.

*Some safety equipment may have been removed or opened to illustrate products clearly and must be in place, and functioning, prior to operation.

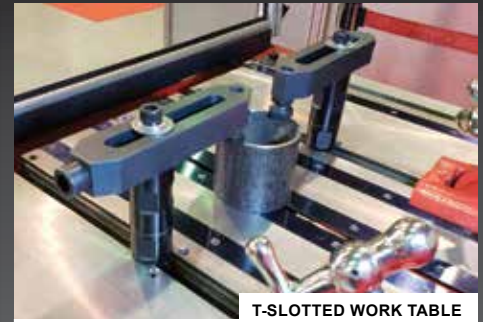

T-SLOTTED WORK TABLE



MITER CUTTING



E14: AIR POWERED VISE



DRO: DIGITAL TILT READOUT



M9A: VARIABLE VISE PRESSURE



ML2: MIST LUBE

PRODUCT SPECIFICATIONS & DIMENSIONS

VT4555 (8-MARK-II)

Rectangular Capacity	Standard Capacity	Optional M6 High Column Capacity
Capacity 90°	18" x 22" (457mm x 558mm)	18" x 28" (457mm x 711mm)
Capacity 45°	18" x 12.75" (457mm x 324mm)	18" x 17" (457mm x 432mm)

Tilt	0 to 45° Left and Right
Drive Motor	5 HP (3.75kw)
Blade Size	14' 6" x 1" x .035" (4420mm x 25mm x 89mm)
Optional M6 High Column Blade Size	15' 6" x 1" x .035" (4724mm x 25mm x 89mm)
Blade Speed Range	50-450fpm (15-137m/min)
Feed Pressure	0-140lbs (0-64kg)



VT4555M (8-MARK-III)

Rectangular Capacity	Standard Capacity	Optional M6 High Column Capacity
Capacity 90°	18" x 22" (457mm x 558mm)	18" x 28" (457mm x 711mm)
Capacity 45° Right	18" x 14.5" (457mm x 368mm)	18" x 18.75" (457mm x 476mm)
Capacity 45° Left	18" x 13" (457mm x 330mm)	18" x 18.3" (457mm x 439mm)
Capacity 60° Right	18" x 9.7" (457mm x 246mm)	18" x 12.5" (457mm x 317mm)
Capacity 60° Left	18" x 7.3" (457mm x 185mm)	18" x 10.25" (457mm x 260mm)
Capacity 3° Forward Cant	17.5" x 22" (445mm x 558mm)	17.5" x 28" (445mm x 711mm)
Round Capacity		
Capacity Nominal	18" (457mm)	18" (457mm)

Tilt	0 to 60° Left and Right
Drive Motor	5 HP (3.75kw)
Blade Size	15' 4" x 1.25" x .042" (4674mm x 32mm x 1.07mm)
Optional M6 High Column Blade Size	16' 4" x 1.25" x .042" (4978mm x 32mm x 1.07mm)
Blade Speed Range	50-450fpm (15-137m/min)
Feed Pressure	0-140lbs (0-64kg)
UL Listed	1-UL Listed



VT4555 (8-MARK-II)

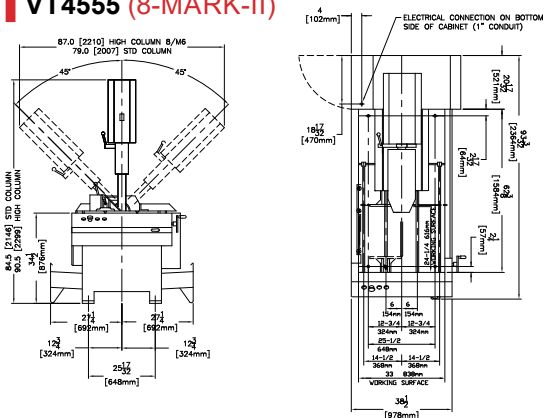

VT4555M (8-MARK-III)

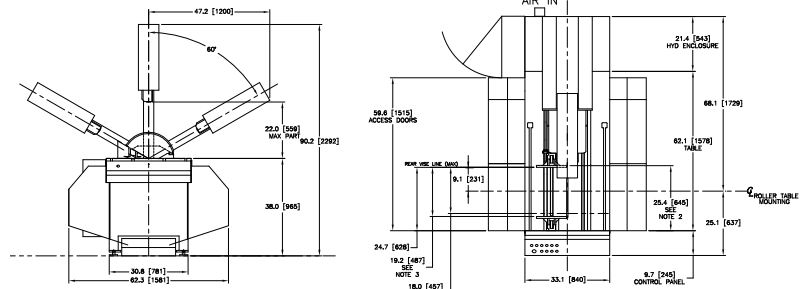

- ⚠ Before using this product, please read the operator's manual carefully and follow all applicable instructions.**
- When using our products, safety equipment is required depending on the operational task.

* Specifications, appearance and equipment are subject to change without notice by reason of improvement.
 * Please use the machine model name as VT455 or VT455M, when applying for administration applications.
 Examples: installation report, export, and financing, ect. To make this catalog more legible, we have inserted hyphens in the model name such as 8-MARK-II and 8-MARK-III.
 * For any inquires, please contact local Amada Machinery America, Inc. office.

© AMADA MACHINERY AMERICA, INC. All Rights Reserved.