

E-Brake 160T-200T Ultra

Press brakes with an E for electronic



160T-200T Ultra



**SAFAN[®]
DARLEY**

The E-evolution in sheet metal working

The E-evolution in sheet metal working increases your competitive strength as a manufacturer

The E-evolution in sheet metal working

As the inventor of the electronic press brake, SafanDarley set in motion a worldwide Evolution in sheet metal working. Even now, SafanDarley continues to work on innovative ways to raise your efficiency levels.



SafanDarley offers innovative solutions for all types of sheet-metal working, applying revolutionary electronic or hydraulic technology. These innovations are the continuation of our previous milestones, such as the first CNCK servo-hydraulic brake press in 1980, the first servo-electronic brake press SMK in 1995, the first hybrid guillotine shearing machine in 1999 and the first fully-fledged electronic brake press, the original E-Brake, in 2004. This revolutionary machine concept started a global 'E-evolution in sheet-metal working'.

SafanDarley now offers a unique programme of electronic press brakes, from the E-Brake 20T Ergonomic to the E-Brake 300T Dual Drive. In the heavier segment too SafanDarley is the leader in innovation, as evidenced by the new generation SafanDarley H-Brake with its unique durable hydraulics.

All SafanDarley machines are operated by means of SafanDarley E-Control, the most user-friendly Man/Machine interface available. The combined expertise of SafanDarley is particularly strong in the field of automated bending cells and client-



specific production solutions, with custom-made machines if so desired.

SafanDarley continues to work on new, more efficient solutions under the motto of 'the E-evolution in sheet-metal working'. Official recognition was on the cards: upon its introduction in 2006, the E-Brake 200T won both the Techni-Show Golden Innovation Award and the Made In Holland Award.



**SAFAN
DARLEY**
E-Brake 160T-200T Ultra

SafanDarley E-Brake 160T-200T Ultra



The E-standard
for Efficiency



The E-standard
for Ergonomics



The E-standard
for Economy



The E-standard
for Ecology



SafanDarley's servo-electronic technology has been proving itself all over the world since 1995. The SafanDarley E-Brake concept constitutes a further improvement on this technology, one that is resulting in ground-breaking performances. Customers are therefore full of praise, especially about the much shorter cycle times, more advantageous use of energy and substantially lower costs for maintenance in comparison with traditional hydraulic press brakes. Based on this extensive practical experience, SafanDarley has effectively adapted the technology and construction to the segment involving weights up to 200 ton and work lengths up to 13 ft. In addition, a strong point of the construction is the level foundation.

**SAFAN
DARLEY**
The E-volution in sheet metal working

Servo-electronic bending with an E for even bending



Roller drive with 4 servo motors



The E-standard for Efficiency

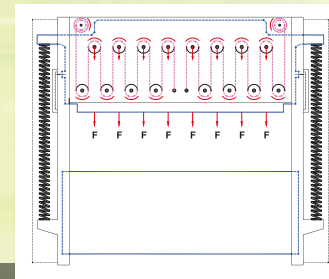

Even distribution of forces

The unique roller drive system in the upper beam ensures a uniform and even distribution of forces. A balanced combination of powerful electro-motors, fixed and movable rollers and specially developed belts facilitate capacities of up to 200T. The flexible belts, which are only 0.12 inch thick and 4 inch wide, are reinforced with steel wires and coated with hard polyurethane. This advanced technology has been extensively tested in the demanding elevator industry. So reliable is the technology that SafanDarley are able to offer a 5 year warranty on the mechanical drive system, when combined with an annual service contract. The special construction of the SafanDarley E-Brake also contributes to the even absorption of large forces. The O-frame acts as a single unit and deformation is kept to an absolute minimum. It is more stable, stronger and produces less deformation than a conventional C-frame.

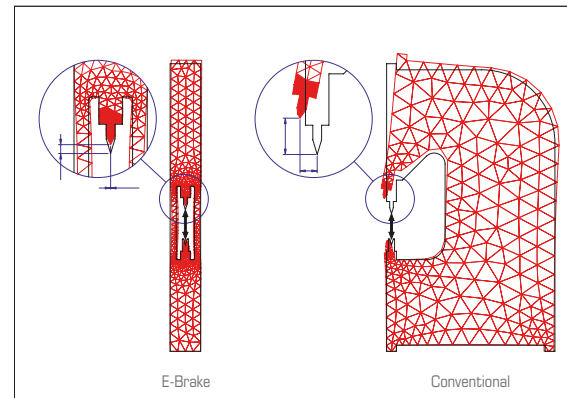

The unique pulley drive of SafanDarley has proven itself around the world

Up to 30% shorter cycle times

The new SafanDarley E-Brake is further optimised to take maximum advantage of the high acceleration and other favourable servo-motor characteristics. For this reason, our SafanDarley E-Brake is very fast throughout the entire cycle.



SafanDarley E-Brake 160T-200T Ultra

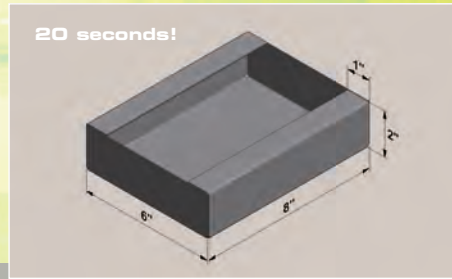

Test product: 20 sec. cycle with SafanDarley E-Brake!



Bending test product

SafanDarley's self-developed controls make use of a new generation of electronics and software. This results in incredibly short reaction and stop times, through which bending speeds of up to 48 inch/min. can be achieved. Cycle times are also far shorter than with conventional press brakes, partly through the fast backgauge.

In comparison tests, the SafanDarley E-Brake is shown to be up to 30% faster than a conventional press brake. Cycle times for this product [see image below]:

SafanDarley E-Brake 160T 3100	Cycle time 20 sec.
Conventional hydraulic press brake	Cycle time 35 sec.

Up to 50% energy saving

The SafanDarley E-Brake only uses energy when the top beam is actually moving. This can deliver an energy saving of up to 50% compared with conventional hydraulic press brakes.

Heavy duty backgauge with a large range

The SafanDarley E-Brake 160-3100 and the E-Brake 200-4100 Ultra are both equipped with a heavy-duty CNC-controlled backgauge system fitted with recirculating ball screws and precision linear ball-bearing guides. The basic model comes complete with CNC-controlled X axis.



The E-standard for Economy

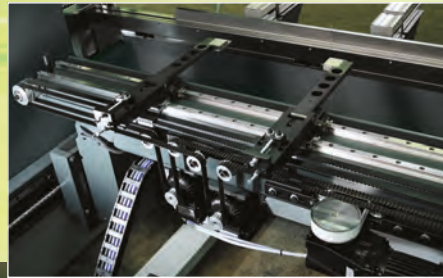

Heavy-duty backgauge

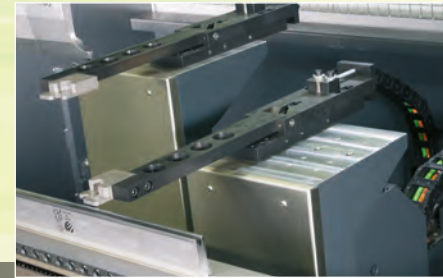

3D backgauge

The standard version of the backgauge has two hinging backgauge fingers that can be manually moved along the bending line (Z axis) as well as adjusted in height (R axis). The stop fingers are provided with interchangeable pins. In optimum use, they permit a maximum backgauge range of 43.3 inch. Optional equipment includes backgauge systems equipped with CNC-controlled R, Z1, Z2 and delta X axis, or full 3D movement with X1, X2, Z1, Z2, R1, and R2 axes.

Tool clamping system

The E-Brake comes with the New Standard Premium MC mechanical tool clamping system. The New Standard Premium HC hydraulic tool clamping system is an option. European Style clamping is also an option (only in combination with a Q-dimension of 25.59 inch).

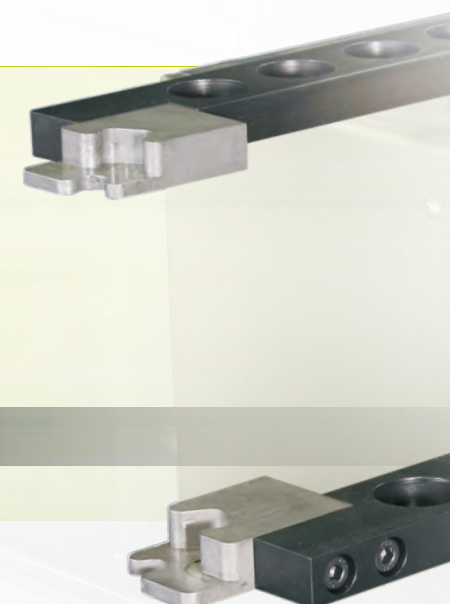

Moveable and adjustable support arms

SafanDarley has developed a range of support arms of modular construction for both light and heavy-duty sheet-metal work. This makes it possible to rapidly set up the correct solution for each application. An optimum combination of ergonomics and efficiency.



Moveable support arms



Moveable support arms adjustable in height

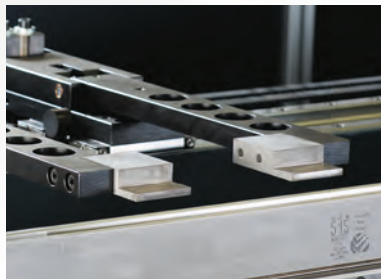

Standard backgauge stops

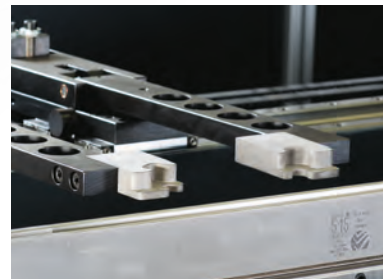

3D backgauge stops

All support arms can be used in combination with the light guard. The support arms are as standard equipped with brushes. You can choose from the following possibilities:

- Support arms fixed to the machine
- Support arms movable across the front side of the machine
- Support arms movable across the front side of the machine and height adjustable with a handwheel
- Support arms movable across the front side of the machine and pneumatically adjustable in height (programmable on the control)

Optionally all support arms can be equipped with adjustable front stops.

SafanDarley E-Control, the new E-standard in ergonomics

Since the introduction in 1995, the SafanDarley E-Controls have been the international standard for ease of operation. The SafanDarley touch screen concept is therefore the most functional and intuitive Man-Machine interface in the sheet-metal working industry. SafanDarley have once again shifted the standards with the SafanDarley E-Control as the latest generation touch screen controls.

The E-standard for Ergonomics

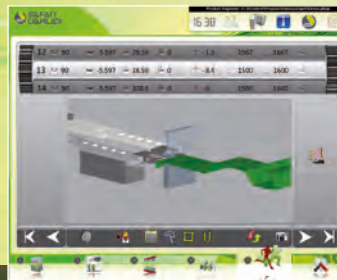

2D bending instructions (EC20)



SafanDarley EC30 control

Complete Touch Screen convenience

The SafanDarley E-Control is fully touch screen, whereby the only buttons visible on the 21" screen are those that are needed during operation. The controls simply run on a PC under Microsoft Windows®, the software was developed based on Microsoft.net Framework. The unit is fitted with a 100 MB Ethernet UTP network connection as standard. The instructions are transmitted to a central processor from the SafanDarley E-Control controls, which in turn regulates the various axis via a so-called CAN-BUS (Control Area Network). The system

can be programmed quickly and accurately thanks to a 'self-teaching' database with data on materials, tools and previous, already corrected bending. The SafanDarley E-Control can be coupled to the majority of off-line programming systems. The standard E-Control 20 facilitates both numeric and 2D graphical programming. It is possible to draw a complete product by means of touch screen and to then automatically generate a bending program. The developed length is also calculated. The optional E-Control 30 can be used to generate 3D drawings.

Web-based communication and support

The controls are set-up for web-based communication such as online diagnoses and loading software updates via the web. Machines can also be coupled to each other in a group and tooling databases can be shared. By monitoring and analysing your operating data online, SafanDarley will be in a position to optimise your production process from a distance in the near future.



Summary of SafanDarley press brake controls EC20 - EC30



SafanDarley Dual screen



2D programming (EC20)

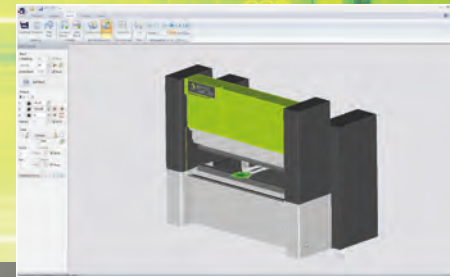

Off-line 3D programming (AutoPOL)



Control type	Possibilities	Off-line connections to
EC20	Numerical product data entry by means of touch screen - extensive tools library - numeric entry of bending parameters - usage of the actual database - 2D programming of products automatic bending sequence calculation with EC Profiler - 2D and 3D graphic display of products programmed offline for Autopol and Radan	- SafanDarley EC software - Delem Profile on Windows - Delem V-Bend - Autopol - Radan
EC30	As EC20, but with graphical 2D and 3D programming and representation of the bending sequence	- SafanDarley EC software - Delem Profile on Windows - Delem V-Bend - Autopol - Radan

Options for optimum ease of operation

Fast, simple and reliable angle measurement can be essential for your bending process. SafanDarley has made E-volution advancements in this area too. Two SafanDarley E-Bend systems, electronically linked to the SafanDarley Touch Screen controls, increase your efficiency through exact sheet thickness or angle measurement.

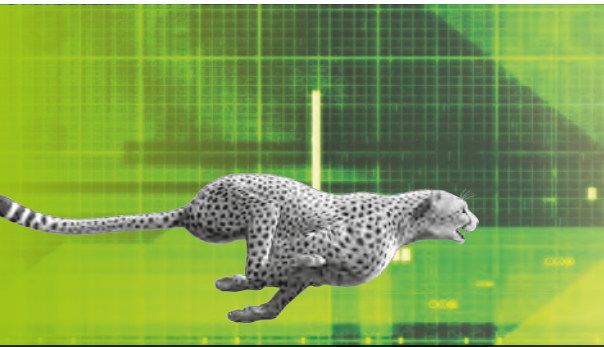

The E-standard for Efficiency

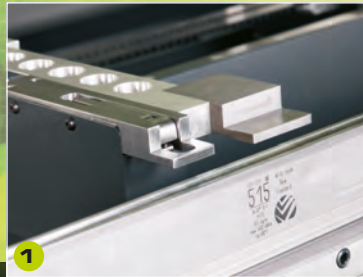

SafanDarley E-Bend S



SafanDarley E-Bend S

The SafanDarley E-Bend S sheet thickness measurement system is mounted next to the backgauge finger. The system measures the sheet thickness to an accuracy of ± 0.0004 inch. It can be precisely programmed when measurement should take place. Measurement takes just tenths of a second and the data in the control system is immediately adjusted. The control system database maintains all records of measurement and is set out graphically.

SafanDarley E-Bend L Blue

The system consists of two laser sensors, one each side of the table that are CNC controlled through the control system. The system continuously monitors and corrects the position of the Y axis on the basis of the actual angle of the product, thereby guaranteeing that the end product has the highest degree of angle precision. Where necessary, the system automatically corrects the crowning and takes the spring-back into account. To that end, the new generation

of E-Bend L Blue is equipped with blue laser sensors. This is because the blue light spectrum is much easier to distinguish from "natural" light, so reflections and sunlight can no longer interfere with the measurement. In addition, combined with the new control platform on the E-Control, the new sensor can perform far more measurements per second. This makes the system more accurate, as it is able to respond to measurements sooner. The E-Bend L Blue (patent pending) can be used in three ways

- Angle measurement with measurement of the spring-back
- Angle measurement with a database
- Angle measurement with learned bending

In the angle measurement with spring-back, the E-Bend L Blue measures at one or three positions during the bending process, corrects the crowning and (Y1 & Y2) positions, and measures the spring-back. These details are then stored in the database. This database is used in angle measurement with a database, making the bending process faster and thus preventing production time from being wasted.



SafanDarley E-Bend L Blue

The most versatile bending aids

The new SafanDarley bending aids provide you with unprecedented flexibility and versatility. For example, both height and V-size are variable and easy to adjust on the bending aid. As a result, the new SafanDarley E-Mate bending aids can be used in conjunction with practically all dies instead of being compatible with only one type of die.



SafanDarley E-Mate plus bending aid



SafanDarley E-Mate 2000

E-Mate plus

- Electrically powered bending aid controlled by an AC Servo motor
- The E-Mate plus has a bending movement of 168,6 lbs
- Movable on linear rails and can be removed using a pallet truck
- Bending aid movements synchronous with that of the pressing beam
- Manual V-groove setting ranging from $V = 0,24''$ to $V = 1,97''$
- Programmable bending speed and retraction speed
- Support arm 47,24" in length, extendable up to 70,87"

E-mate 2000

- Electrically powered bending aid controlled by an AC Servo motor
- The E-Mate 2000 has a bending movement of 1475"/lbs
- Movable on linear rails and can be removed using a pallet truck
- Bending aid movements synchronous with that of the pressing beam
- Manual V-groove setting ranging from $V = 0,24''$ to $V = 5,91''$
- Programmable bending speed and retraction speed
- Table with steel rollers, 23,62" x 39,37", equipped with extended support arm of up to 62,99"

Electronic evolution with an E for ecological and economical

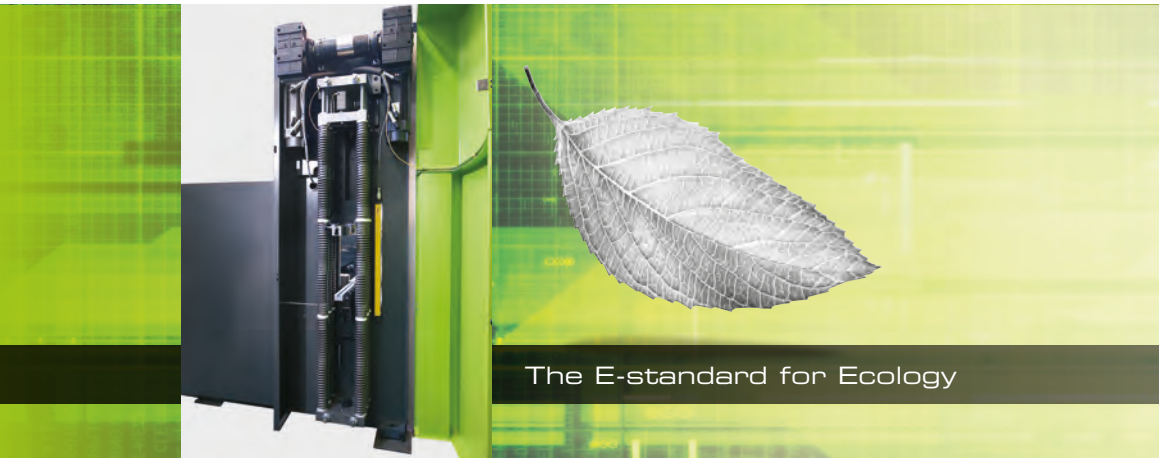

Side view

The SafanDarley E-Brake contributes perfectly to your sustainable business, while at the same time making your business operations much more economic. The absence of hydraulics means that the problems associated with environmentally harmful and risky oil are a thing of the past.

There is no need to adjust the settings of pressure relief valves – with the risk of mistakes and drift – and there are no filters to be checked and replaced. The servo-electronic system is therefore far more reliable than the hydraulic one, because of the lack of oil, tanks, pumps, seals, valves and filters. And you will never have trouble with a cold start up.

Integrated safety

Work fast without risk: SafanDarley makes that a reality with the safety system integrated within the controls. It works with a safety light screen that is automatically directed from the SafanDarley E-Control. In addition, the SafanDarley E-Brake has an additional in-built safety provision. The application of a spring return means that the top beam will always move upwards in the event of a failure.



Turn-key delivery of automated bending solutions

In 1988, SafanDarley had already installed the first robotic press brake in Europe. SafanDarley is now an experienced specialist in the field of automated bending cells including the standard SafanDarley R-Brake. The SafanDarley integral solutions for your production process go much further than stand-alone solutions.

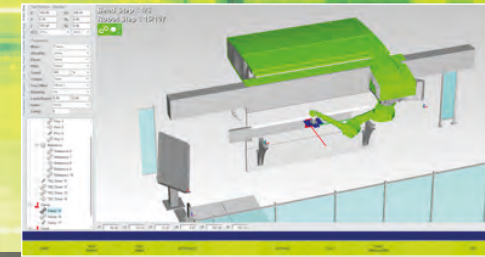

Off-line programming

The integral automation is not restricted to the bending cell alone, this also applies to other parts of the process such as punching and spot-welding, and the entire routing of sheet material around the bending cell.

Flexible solutions and off-line software

You retain your flexibility with SafanDarley in terms of new products or changes in your production process. You are also flexible in relation to coupling with external systems and choosing your robot. The SafanDarley

E-Brake is perfectly suited to operate as a mid-point for every automated bending cell. The SafanDarley controls run under the Windows® platform, adding a whole range of options for links, networks, software packages and resolving downtime of the unmanned production process over the Internet. SafanDarley can supply complete, fully tested programs for both new and existing robotic cells. You have a choice between off-line or parametric programming. Naturally, you can contract out all programming to SafanDarley.

The SafanDarley RoboBend off-line programming is a guarantee for maximum efficiency of your bending cell. All movements can be programmed and simulated in advance.

From advice & consultancy to manufacturing

SafanDarley makes automation of sheet-metal working easier than you think. This starts with the convenience of a single contact person for the entire project. Our consultants clearly present you with the entire range of options, enabling you to make the best possible choice for your production

process. SafanDarley develops and realises turnkey solutions for bending and cutting systems with guaranteed cycle times. This fixes the costs per product. The return time of your investment can be properly determined based on those set costs. With the help of a simulation model, you will get a reliable indication beforehand of your expected Return On Investment.

SafanDarley E-Brake energy consumption

On the SafanDarley E-Brake, the main drive motor is used only when the E-Brake has to actually perform a movement. With a conventional hydraulic press brake, the hydraulic pump motor is running all the time.

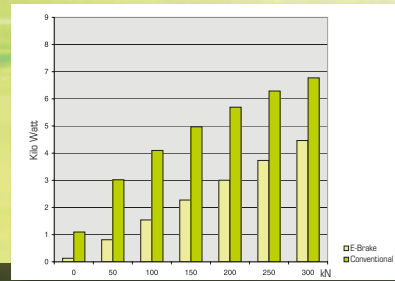

SafanDarley E-Brake energy consumption

The graph above only covers the time while the press brake is actually in operation. During the stand-by time - which can be as much as 90% on account of sheet handling, conversion and intervals - this will mean a further saving with the SafanDarley E-Brake up to 3000 kWh a year.

Standard features

- SafanDarley EC20 Touch Screen CNC press brake controls
- CNC-controlled R- axis
- CNC-controlled Y1-Y2 axis (top beam adjustable inclined +/- 0.1 inch)
- CNC-controlled backgauge (X-axis) with a wide range
- Manual adjustment of 2 backgauge fingers across a linear parallel guide
- NSCL II MC Premium top tool mechanical clamping system and NSCL II MC Premium crowning
- Built in size of 23.22 inch (Q-dimension)
- 2 Support arms (11.81 inch)
- 1 Hold to Run operating console
- Programmable and integrated safety light guard
- Safety in compliance with CE

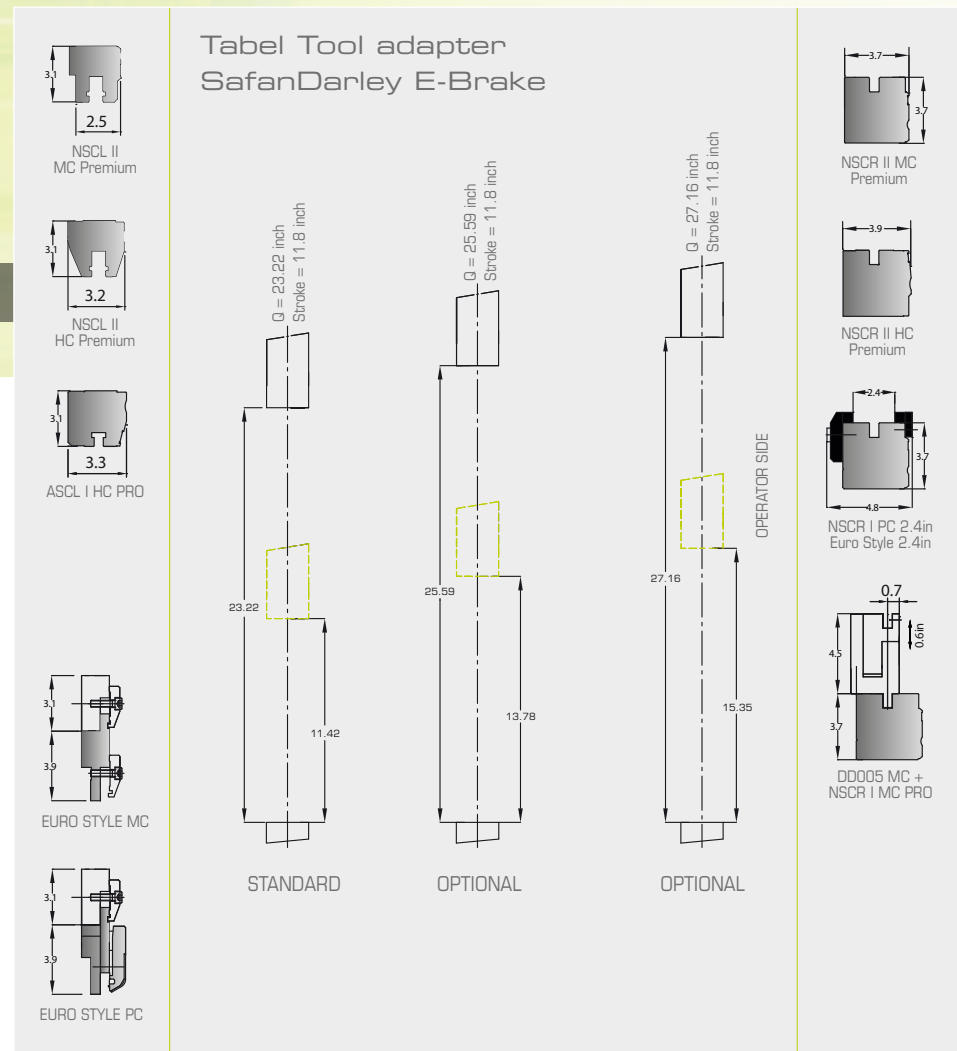

Technical specifications

SafanDarley E-Brake 160 - 200T Ultra

E-Brake 160T-200T Ultra	Pressure force in US ton.	Working length in inch	Maximum stroke in inch	Q size in inch	Closing speed in inch/min.	Bending speed max. in inch/min.	Return speed in inch/min.	Motor Power in kW	Weight in Lbs.	A in inch	B in inch	C in inch	D in inch
160-3100	176	120	12	23*	236	48**	236	22	33,069	120	177	114	122
200-4100	220	160	12	23*	177	48**	177	22	40,786	160	216	114	122

* Q size: Optional 25.59 or 27.16 inch

** CE version: Max. bending speed 24 inch/min.

(Subjects to modifications)

Accessories (optional)

- CNC-controlled Z1-Z2 axis (horizontal repositioning back gauge fingers)
- CNC-controlled Delta X-axis (horizontal repositioning of one backgauge finger)
- CNC-controlled 3D backgauge (X1-X2-R1-R2-Z1-Z2)
- Built in size of 25.59 inch or 27.16 inch (Q-dimension)
- Various upper and lower tool adaptors
- Various bending aids
- SafanDarley E-Bend S sheet thickness measurement system
- SafanDarley E-Bend L Blue angle measurement system
- Various support arms, fixed, moveable and adjustable in height where required
- Extra Hold To Run operating console for stage bending
- Integrated tool cabinet
- Machine lighting
- SafanDarley E-Control press brake control:
 - EC30 control, complete 2D and 3D graphic programming

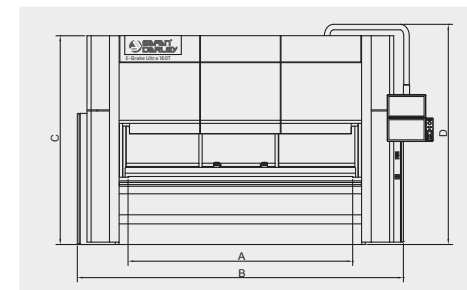
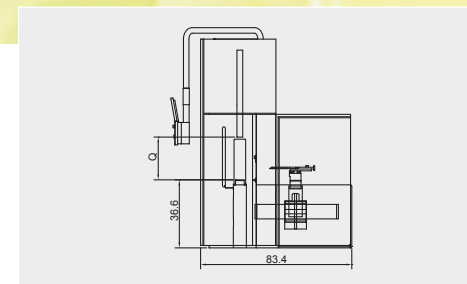
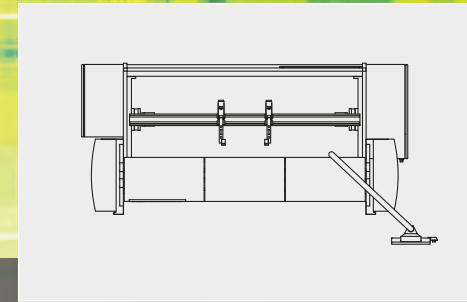



E-Brake 35T-40T
Premium Ergonomic



E-Brake 35T-130T Premium



E-Brake 160T-200T Ultra



E-Brake 50T-130T Ultra



E-Brake 300T Ultra Dual Drive



E-Brake 35T Mini Cell



E-Brake 160T-200T ITC



H-Brake Hybrid 110T-1600



H-Brake Hybrid 110T-170T
Premium



H-Brake Hybrid 110T-170T
Ultra



H-Brake 175T-400T
Ultra

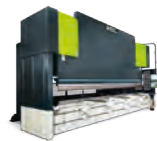

H-Brake HD 500T-1250T
Ultra



R-Brake 130T

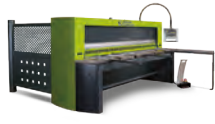

B-Shear & M-Shear



Special cutting lines



SafanDarley North America, LLC, 9070 Junction Drive,
Annapolis Junction, Maryland 20701 USA, T. 410-807-8008

SafanDarley B.V., Kwinkweerd 11, NL-7241 CW Lochem
P.O. Box 96, NL-7240 AB Lochem, The Netherlands
Tel.: +31 (0)573 222 222, Fax: +31 (0)573 222 299

E-mail: info@safandarley.com, Website: www.safandarley.com



Watch our corporate
movie here: